

Screw-In™ Drive Screw Anchors



Description

The Screw-In Drive Screw Anchor is a **2-piece drive screw anchor** comprised of a corrosion resistant zamac anchor body and steel Phillips screw pin. The #2 Phillips screw pin can be **easily removed** after the anchor is properly set. The Screw-In anchor is ideal for light-duty applications in concrete, block, brick or stone.

Key Features & Benefits

- ▶ Pre-assembled, ready to use
- ▶ Screw can be easily removed after anchor is properly set
- ▶ Easy to install in concrete, block, brick or stone

Applications

- ▶ Roof Flashing
- ▶ Masonry Anchorage and Brick Ties
- ▶ Electrical Fixtures
- ▶ Mechanical Attachments
- ▶ Furring Strips
- ▶ Brackets



Specifications, Listings and Approvals

Diameters: 1/4"

Materials:

Anchor Body: Die Cast Zamac Alloy

Screw: Zinc-Plated Cold Rolled Steel

Installation Information

Instructions

1. Drill the hole perpendicular to the work surface at least 1/4" deeper than the calculated embedment depth. Clean the hole using compressed air and a nylon brush.
2. Insert anchor assembly through mounting holes in fixture and into anchor hole.
3. Gently hammer screw flush to expand body.
- 4 **To remove:** Using a Phillips screw driver, turn counter clockwise until screw is removed from anchor body. Set the claw of a hammer between the anchor body and fixture and pull loose.

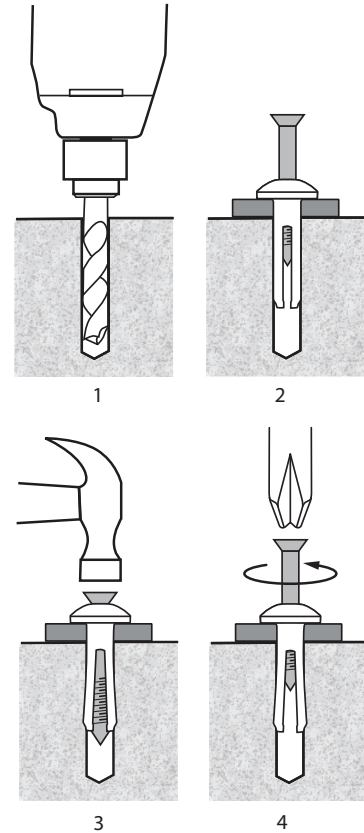

Installation Data

Anchor Dia. (in.)	Drill Bit Dia. (in.)	Fixture Clearance Hole (in.)	Head Height (in.)	Head Width (in.)	Screw Style
1/4	1/4	5/16	3/16	35/64	#2 Phillips

Performance Data

Ultimate and Allowable Loads (lbs.) – Normal-Weight Concrete

Anchor Diameter (in.)	Minimum Embedment Depth (in.)	Allowable						Ultimate					
		2,000 psi		4,000 psi		6,000 psi		2,000 psi		4,000 psi		6,000 psi	
		Tension	Shear	Tension	Shear	Tension	Shear	Tension	Shear	Tension	Shear	Tension	Shear
1/4	5/8	175	165	220	225	230	225	700	660	880	900	920	900
	3/4	205	200	285	285	295	285	820	800	1140	1140	1180	1140
	7/8	240	255	305	310	313	310	960	1020	1220	1240	1250	1240
	1-1/8	315	345	345	375	363	375	1260	1380	1380	1500	1450	1500
	1-3/8	340	390	365	415	380	420	1360	1560	1460	1660	1520	1680
	1-3/4	380	460	400	480	415	485	1520	1840	1600	1920	1660	1940
	1-7/8	380	460	400	480	415	485	1520	1840	1600	1920	1660	1940

*Allowable load capacities are calculated using an applied safety factor of 4:1

Ultimate and Allowable Loads (lbs.) – Hollow Concrete Masonry

Anchor Diameter (in.)	Minimum Embedment Depth (in.)	1,500 psi			
		Allowable		Ultimate	
		Tension	Shear	Tension	Shear
1/4	5/8	95	220	380	880
	3/4	160	240	640	960
	1	190	245	760	980
	1-1/8	220	255	880	1020
	1-3/8	225	260	900	1040
	1-1/2	225	260	900	1040

*Allowable load capacities are calculated using an applied safety factor of 4:1

Ultimate and Allowable Loads (lbs.) - Solid Clay Brick Masonry

Anchor Diameter (in.)	Minimum Embedment Depth (in.)	1,500 psi			
		Allowable		Ultimate	
		Tension	Shear	Tension	Shear
1/4	5/8	145	300	580	1200
	3/4	195	340	780	1360
	1	210	340	840	1360
	1-1/8	20	340	80	1360
	1-3/8	240	340	960	1360
	1-1/2	260	340	1040	1360

*Allowable load capacities are calculated using an applied safety factor of 4:1

Order Information



Drive Screw Anchors: Zamac Allow Body with Steel Screw

Catalog No.	Anchor Size (in.)	Screw Style	Box Quantity	Carton Quantity
DNHS1403	1/4 x 3/4	#2 Phillips	100	1000
DNHS1410	1/4 x 1	#2 Phillips	100	1000
DNHS1411	1/4 x 1-1/4	#2 Phillips	100	1000
DNHS1412	1/4 x 1-1/2	#2 Phillips	100	800
DNHS1420	1/4 x 2	#2 Phillips	100	800
DNHS1422*	1/4 x 2-1/2	#2 Phillips	100	800
DNHS1430*	1/4 x 3	#2 Phillips	100	800

* Special Order

For more information, please contact:

TOGGLER[®]
HIGH-PERFORMANCE ANCHORS[®]

wej-it[®]
HIGH-PERFORMANCE ANCHORS

Divisions of Mechanical Plastics Corp.
110 Richards Avenue • Norwalk, CT 06854

Phone: 203-857-2200

Fax: 203-857-2201 • E-mail: sales@wej-it.com

www.togglor.com • www.wej-it.com

Screw-In™, TOGGLER logo and typeface, Wej-It® and High-Performance Anchors® are trademarks of Mechanical Plastics Corp. ©2015 Mechanical Plastics Corp. Rev. 8/15