

Hollo Set™ Drop-In Anchors

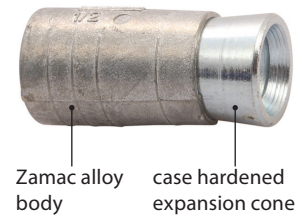

Description

The Hollo Set drop-in anchor is an **internally threaded**, flush mount expansion anchor designed for use in hollow and solid base materials. In hollow concrete block and precast hollow core plank, the outer wall is generally 1-1/2" thick. When a hole is drilled into the material, there is often spalling on the back side of the wall that can decrease the wall thickness to less than 1" thick. The Hollo Set anchor will still provide high performance in these altered applications, unlike similar products.



Key Features & Benefits

- ▶ Easy to install using a hammer (or mallet) and a setting tool
- ▶ Internally threaded anchor allows easy bolt removability and service work
- ▶ Two-piece anchor comprised of a zamac anchor body and a case hardened steel expansion cone insert
- ▶ The anchor offers consistent holding power in
 - normal weight concrete
 - hollow concrete masonry (CMU)
 - precast hollow core plank
 - masonry/brick

Applications

- ▶ Conduit
- ▶ Cable Trays & Strut
- ▶ Pipe Supports
- ▶ Fire Sprinklers
- ▶ Suspended Lighting
- ▶ Removable Applications

Specifications, Listings and Approvals

Anchor Thread Diameters: 1/4" - 1/2"

Materials:

Anchor body: Zamac alloy

Expansion Cone: AISI C1018

Plating: ASTM B633, SC1, Type III (Fe/Zn 5)

Installation Information

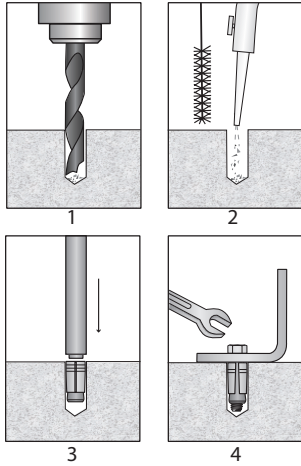

Instructions for Solid Base Materials

1. Drill the hole perpendicular to the work surface at the required embedment depth.
2. Clean the hole using compressed air and a nylon brush.
3. Insert the anchor into the hole with the expansion cone facing downward. Put the Solid-Base Setting Tool into the anchor and strike with a hammer to engage the expansion cone.
4. Insert the bolt through the fixture and tighten.

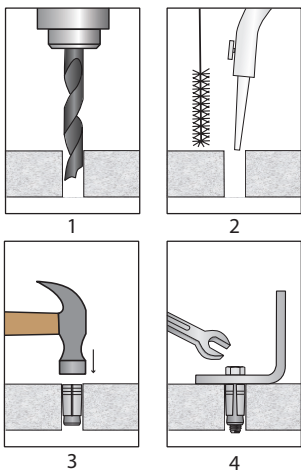

Instructions for Hollow Base Materials

1. Drill the hole perpendicular to the work surface into the hollow cavity of the substrate.
2. Clean the hole using compressed air and a nylon brush.
3. Insert the anchor into the hole with the expansion cone facing downward and tap flush to the level of the work surface.
4. Insert the bolt through the fixture and tighten.
 - When using the hollow base Setting Tool, thread anchor into tool before tapping into anchor hole. Turn setting tool clockwise to tighten.

NOTE: Always wear safety glasses. Follow drill manufacturer's instructions. Use only solid carbide-tipped drill bits meeting ANSI B212.15 diameter standards.

Installation Data

Catalog No.	Anchor Thread Dia. (in.)	Thread Size (UNC)	Drill Bit Dia. (in.)	Thread Length in Cone (in.)	Sleeve Length (in.)	Overall Length (in.)	Installation Torque Approx. (ft.-lbs.)
WDHS14	1/4	1/4-20	3/8	3/8	5/8	7/8	3-4
WDHS38	3/8	3/8-16	5/8	5/8	15/16	1-5/16	8-10
WDHS12	1/2	1/2-13	3/4	3/4	1-1/4	1-3/4	15-20

Performance Data

Ultimate and Allowable Loads (lbs.) – Normal-Weight Concrete

Anchor Thread Dia. (in.)	Min. Embed. Depth (in.)	Drill Bit Dia. (in.)	Allowable						Ultimate					
			2,000 psi		4,000 psi		6,000 psi		2,000 psi		4,000 psi		6,000 psi	
			Tension	Shear	Tension	Shear	Tension	Shear	Tension	Shear	Tension	Shear	Tension	Shear
1/4	3/4	3/8	185	295	260	300	335	305	740	1180	1040	1200	1340	1220
	7/8		205	353	280	358	355	363	820	1410	1120	1430	1420	1450
3/8	1	5/8	353	620	453	625	553	630	1410	2480	1810	2500	2210	2520
	1-1/2		555	768	705	773	1215	778	2220	3070	2820	3090	4860	3110
1/2	1-1/2	3/4	590	955	1060	970	1640	990	2360	3820	4240	3880	6560	3960
	2		730	960	1198	975	2128	1000	2920	3840	4790	3900	8510	4000

*Allowable load capacities are calculated using an applied safety factor of 4:1

Ultimate and Allowable Loads (lbs.) – Hollow Core Plank

Anchor Thread Dia. (in.)	Min. Embed. Depth (in.)	Drill Bit Dia. (in.)	5,000 psi			
			Allowable		Ultimate	
			Tension	Shear	Tension	Shear
1/4	7/8	3/8	313	360	1250	1440
3/8	1	5/8	503	628	2010	2510
	1-1/2		955	775	3820	3100
1/2	1-1/4	3/4	1350	980	5400	3920

*Allowable load capacities are calculated using an applied safety factor of 4:1

Ultimate and Allowable Loads (lbs.) – Solid Brick Masonry

Anchor Thread Dia. (in.)	Min. Embed. Depth (in.)	Drill Bit Dia. (in.)	1,500 psi			
			Allowable		Ultimate	
			Tension	Shear	Tension	Shear
1/4	7/8	3/8	165	318	660	1270
3/8	1-1/2	5/8	445	690	1780	2760
1/2	1-1/4	3/4	530	860	2120	3440

*Allowable load capacities are calculated using an applied safety factor of 4:1

Ultimate and Allowable Load (lbs.) – Hollow Concrete Masonry

Anchor Thread Dia. (in.)	Min. Embed. Depth (in.)	Drill Bit Dia. (in.)	1,500 psi			
			Allowable		Ultimate	
			Tension	Shear	Tension	Shear
1/4	7/8	3/8	158	260	630	1040
3/8	1	5/8	300	558	1200	2230
1/2	1-1/4	3/4	473	860	1890	3440

*Allowable load capacities are calculated using an applied safety factor of 4:1

Load Adjustment Factors

Spacing – Tension & Shear

Anchor Thread Dia.	1/4	3/8	1/2
Embedment h_v	7/8	1-1/2	2
Critical Spacing S_{cr}	2-5/8	4-1/2	6
Min. Spacing S_{min}	1-3/8	2-1/4	3
Actual Spacing S_{act}	1-3/8	0.50	–
	2-1/4	0.86	0.50
	2-5/8	1.00	0.58
	3	–	0.67
	4-1/2	–	1.00
	5	–	–
6	–	–	1.00

For tension and shear anchor loads, the critical spacing (S_{cr}) is equal to 3 embedment depths at which the anchor achieves 100% of load. Minimum spacing (S_{min}) is equal to 1.5 embedment depths ($1.5h_v$) at which the anchor achieves 50% of load.

Edge Distance – Tension

Anchor Thread Dia.	1/4	3/8	1/2
Critical Edge Dist. C_{cr}	3-1/2	5-1/4	7
Min. Edge Dist. C_{min}	2	3	4
Actual Edge Dist. C_{act}	2	0.80	–
	2-1/2	0.87	–
	3	0.93	0.80
	3-1/2	1.00	0.84
	4	–	0.89
	5-1/4	–	1.00
	6	–	–
	7	–	–

For tension anchor loads, the critical edge distance (C_{cr}) is equal to 14 anchor diameters at which the anchor achieves 100% of load. Minimum edge distance (C_{min}) is equal to 8 anchor diameters at which the anchor achieves 80% of load.

Edge Distance – Shear

Anchor Thread Dia.	1/4	3/8	1/2
Critical Edge Dist. C_{cr}	3-1/2	5-1/4	7
Min. Edge Dist. C_{min}	2	3	4
Actual Edge Dist. C_{act}	2	0.50	–
	3	0.83	0.50
	3-1/2	1.00	0.61
	4	–	0.72
	5-1/4	–	1.00
	7	–	–

For shear anchor loads, the critical edge distance (C_{cr}) is equal to 14 anchor diameters at which the anchor achieves 100% of load. Minimum edge distance (C_{min}) is equal to 8 anchor diameters at which the anchor achieves 50% of load.

Order Information



Hollo Set Drop-In Anchors: Zinc-Plated Carbon Steel

Catalog No.	Drill Bit Dia. (in.)	Thread Size (UNC)	Anchor Length (in.)	Box Quantity	Carton Quantity
WDHS14	3/8	1/4 - 20	7/8	100	1000
WDHS38	5/8	3/8 - 16	1-5/16	50	500
WDHS12	3/4	1/2 - 13	1-3/4	50	500



Setting Tools: Solid-Base Materials

Catalog No.	Sets Anchor Thread Size (in.)	Quantity
STH14	1/4	1
STH38	3/8	1
STH12	1/2	1

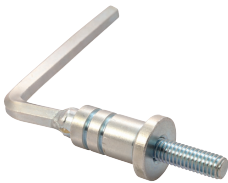

Setting Tools: Hollow-Base Materials

Catalog No.	Sets Anchor Thread Size (in.)	Quantity
STSH14	1/4	1
STSH38	3/8	1
STSH12	1/2	1

For more information, please contact:



Divisions of Mechanical Plastics Corp.
110 Richards Avenue • Norwalk, CT 06854

Phone: 203-857-2200
Fax: 203-857-2201 • E-mail: sales@wej-it.com
www.togglers.com • www.wej-it.com