

Hang-TITE™ Rod Hanger Screws



Description

The Hang-TITE Rod Hanger Screw is a **one-piece**, internally threaded anchor designed for suspending threaded rod for applications like cable-tray, pipe hanging, fire protection, and electrical conduit. It can be installed in a variety of base materials like wood frame columns and beams, steel purlins, bar joists and beams, and concrete ceilings, beams and columns. The Hang-TITE screws made for steel and wood applications are also available in a side mount style. Socket driver tools are available for easy installation using a screw gun or hammer drill.

Key Features & Benefits

- ▶ **One-piece** anchor design
 - Screw portion of the anchor will not prematurely break away from the anchor head
- ▶ **Universal socket** can be used for all Steel and Wood Hang-TITE screws
- ▶ Horizontal (side) mount available for both Steel and Wood Hang-TITE screws
- ▶ Lower in-place cost when compared to lag screws, drop-in anchors, and beam clamps
- ▶ Rapid installation for overhead applications
 - All Hang-TITE screws can be installed using a screw gun or hammer drill

Applications

- ▶ Cable-Tray
- ▶ Suspended Ceilings
- ▶ HVAC Ductwork
- ▶ Strut channels
- ▶ Electrical Conduit
- ▶ Hanging pipe
- ▶ Sprinkler systems



Wood - Vertical



Wood - Horizontal

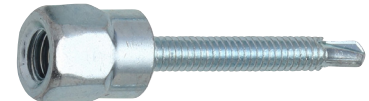

Steel - Vertical



Steel - Horizontal



Concrete - Vertical



Specifications, Listings and Approvals

Materials:

- Carbon steel with zinc plating
- Case hardened C1022
- ASTM B633 Type III

Internal Thread Range (UNC):

- 1/4", 3/8", 1/2" Wood
- 1/4", 3/8", 1/2" Steel
- 1/4", 3/8", 1/2" Concrete

Installation Information

Instructions – Wood

1. Mount the Universal Steel & Wood Socket Drive (Part No. HTWSST) into the chuck of the drill.

NOTE: Certain types of wood truss/wood joint require pre-drilling with a 1/8" diameter bit

2. Insert the head of the anchor into the socket driver.
3. Press the tip of the anchor against the wood surface [or press tip into pre-drilled hole, if needed].
4. Install with a smooth, steady motion until the anchor is firmly seated against the wood.
5. Thread the appropriate diameter steel threaded rod or threaded bolt into the anchor. The threaded rod or bolt should fully engage the thread length of the anchor.

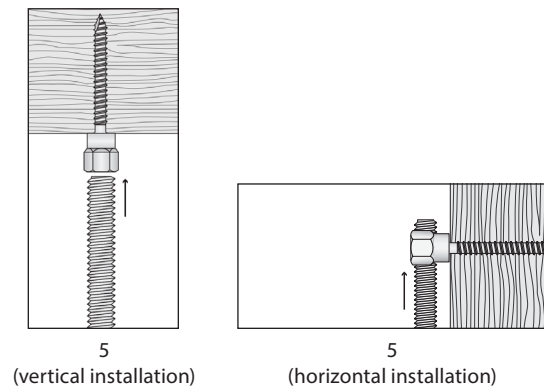
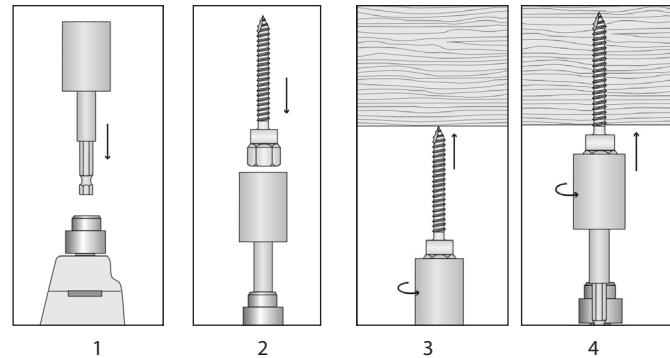

Instructions – Steel

1. Mount the Universal Steel & Wood Socket Drive (Part No. HTWSST) into the chuck of the drill.
2. Insert the head of the anchor into the socket driver.
3. Press the tip of the anchor against the steel surface and install with a smooth, steady motion until the anchor is firmly seated against the steel. No pre-drilling is required.
4. Add the retainer nut [if needed].
5. Thread the appropriate diameter steel threaded rod or threaded bolt into the anchor. The threaded rod or bolt should fully engage the thread length of the anchor.

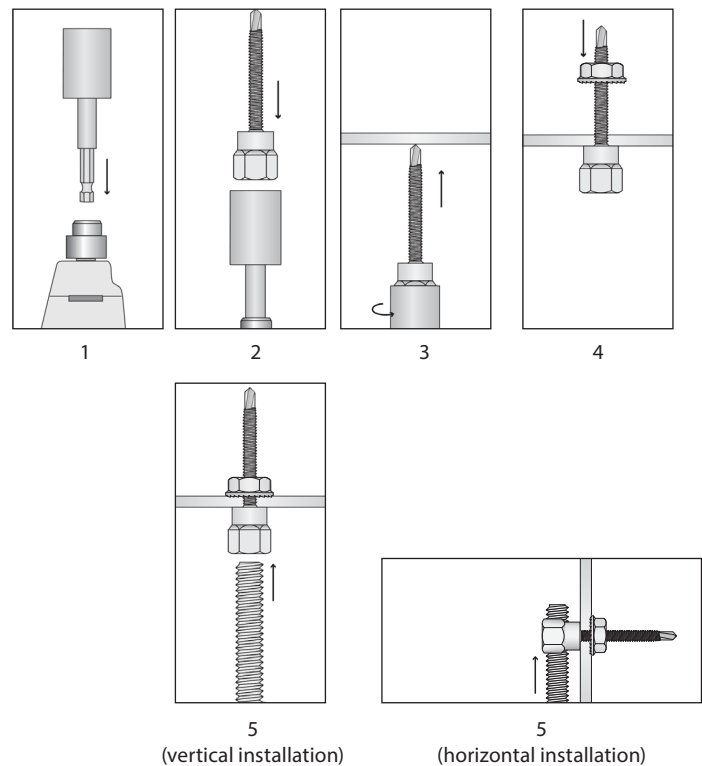

Instructions – Concrete

1. Use the correct size masonry drill and drill the hole at least one anchor diameter deeper than the calculated embedment depth. Clean the hole using a nylon brush and compressed air.
2. Select the appropriate size socket driver (Part No. HTCST14, HTCST38 or HTCST12) and mount it into the chuck of the drill.
3. Insert the head of the anchor into the socket driver.
4. Press tip into pre-drilled hole and install with a smooth, steady motion until the anchor is firmly seated against the concrete.
5. Thread the appropriate diameter steel threaded rod or threaded bolt into the anchor. The threaded rod or bolt should fully engage the thread length of the anchor.

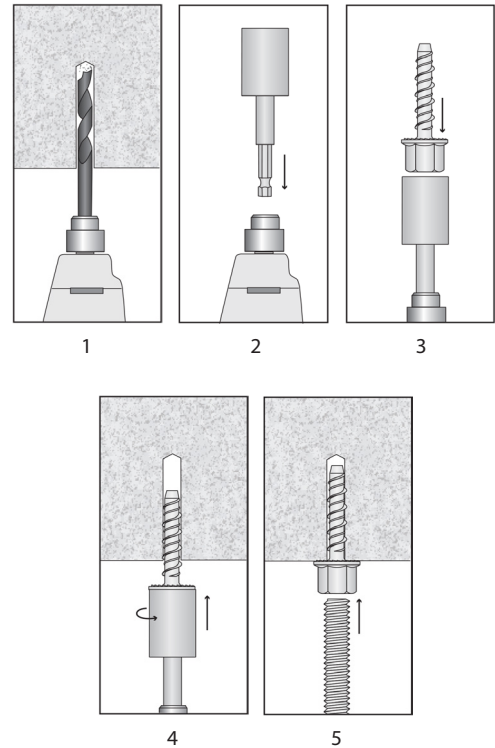

Installation Data

Wood – Screw

Screw Size (in.)	Point Style	Shank Length (in.)	*Drill Bit Diameter (in.)
1/4 Thread Forming	Type 17	1/4	1/8
3/8 Thread Forming	Type 17	1/4	1/8

*If required

Steel – Screw

Screw Thread Size	Point Style	Self Drilling Range	Root Dia. (in.)	Drill Speed (RPM)
1/4 - 20	#3	0.036" (20 gauge) – 0.188" (3/16")	13/64	500 - 1,500
#12 - 20	#5	0.188" (3/16") – 0.500" (1/2")	13/64	500 - 1,500

Steel & Wood – Coupling

Rod Dia. (in.)	Coupling Type	Coupling Thread Size (UNC)	Coupling Thread Depth (in.)	Coupling Width (in.)	Coupling Height (in.)
1/4	Vertical	1/4 - 20	3/8	5/8	13/16
3/8	Vertical	3/8 - 16	3/8	5/8	13/16
1/2	Vertical	1/2 - 13	3/8	5/8	13/16
1/4	Horizontal	1/4 - 20	5/8*	5/8	13/16
3/8	Horizontal	3/8 - 16	5/8*	5/8	13/16

* Side Hang-TITE anchors have an open end internal threading.

Concrete

Rod Dia. (in.)	Drill Bit Dia. (in.)	Overall Screw Shank Length	Anchor Thread Length (in.)	Coupling / Washer Height (in.)	Washer O.D. (in.)	Thread Size (UNC)	Thread Depth (in.)	Socket Driver Size (in.)
1/4	1/4	1-1/4	1-1/8	27/64	31/64	1/4-20	3/8	3/8
3/8	1/4	1-1/2	1-3/8	9/16	39/64	3/8-16	1/2	1/2
1/2	3/8	2-3/4	2-1/2	13/16	31/32	1/2-13	3/4	11/16

Performance Data

Wood: Ultimate and Allowable Tension Loads (lbs.)

Rod Dia. (in.)	Style	Screw Thread Size and Length (in.)	Embed. Depth (in.)	Allowable			Ultimate		
				Fir	Pine	Spruce	Fir	Pine	Spruce
1/4	Vertical	1/4 x 1	1	170	160	160	680	640	640
3/8	Vertical	1/4 x 1	1	170	160	160	680	640	640
	Vertical	1/4 x 2	2	375	375	375	1500	1500	1500
	Vertical	1/4 x 3	3	518	375	375	2070	1500	1500
	Vertical	3/8 x 2-1/2	2-1/2	663	775	775	2650	3100	3100
	Horizontal	1/4 x 1	1	170	160	160	680	640	640
	Horizontal	1/4 x 2	2	448	448	448	1790	1790	1790
	Horizontal	3/8 x 2-1/2	2-1/2	368	390	353	1470	1560	1410
1/2	Vertical	3/8 x 2-1/2	2-1/2	663	775	775	2650	3100	3100

*Allowable load capacities are calculated using an applied safety factor of 4:1

Steel: Allowable Tension Loads (lbs.) – ASTM A 36 Steel (Beams) and ASTM A 572 Steel (Purlins)

Rod Dia. (in.)	Style	Screw Thread Size and Length (in.)	Minimum Steel Gauge (Thickness)					
			20	18	16	14	12	3/16"
1/4	Vertical	1/4-20 x 1 (w/nut)	385	385	443	443	510	958
	Vertical	1/4-20 x 1	103	158	248	288	383	795
3/8	Vertical	1/4-20 x 1 (w/nut)	385	385	443	443	510	958
	Vertical	1/4-20 x 1-1/2	103	158	248	288	383	795
	Vertical	12-20 x 1-1/2 (w/nut)	385	385	443	443	510	958
	Horizontal	1/4-20 x 1-1/2 (w/nut)	385	385	443	443	510	958
	Horizontal	1/4-20 x 1-1/2	103	158	248	288	383	490
1/2	Vertical	12-20 x 1-1/2	125	180	238	385	503	825
	Vertical	12-20 x 1-1/2 (w/nut)	385	385	443	443	510	958

*Allowable load capacities are calculated using an applied safety factor of 4:1

Steel: Ultimate Tension Loads (lbs.) – ASTM A 36 Steel (Beams) and ASTM A 572 Steel (Purlins)

Rod Dia. (in.)	Style	Screw Thread Size and Length (in.)	Minimum Steel Gauge (Thickness)					
			20	18	16	14	12	3/16"
1/4	Vertical	1/4-20 x 1 (w/nut)	1540	1540	1770	1770	2040	3830
	Vertical	1/4-20 x 1	410	630	990	1150	1530	3180
3/8	Vertical	1/4-20 x 1 (w/nut)	1540	1540	1770	1770	2040	3830
	Vertical	1/4-20 x 1-1/2	410	630	990	1150	1530	3180
	Vertical	12-20 x 1-1/2 (w/nut)	1540	1540	1770	1770	2040	3830
	Horizontal	1/4-20 x 1-1/2 (w/nut)	1540	1540	1770	1770	2040	3830
	Horizontal	1/4-20 x 1-1/2	410	630	990	1150	1530	1960
1/2	Vertical	12-20 x 1-1/2	500	720	950	1540	2010	3300
	Vertical	12-20 x 1-1/2 (w/nut)	1540	1540	1770	1770	2040	3830

*Allowable load capacities are calculated using an applied safety factor of 4:1

Concrete: Allowable Loads (lbs.) – Normal-Weight Concrete

Rod Dia. (in.)	Style	Screw Thread Size and Length (in.)	Drill Bit Dia. (in.)	Embed. Depth (in.)	Allowable					
					2,000 psi		4,000 psi		6,000 psi	
					Tension	Shear	Tension	Shear	Tension	Shear
1/4	Vertical	1/4 x 1-1/4	1/4	1-1/4	345	450	485	605	515	635
3/8	Vertical	1/4 x 1-1/2	1/4	1-1/2	435	640	645	655	685	680
1/2	Vertical	3/8 x 2-3/4	3/8	2-3/4	1325	1305	1500	1575	2145	1850

*Allowable load capacities are calculated using an applied safety factor of 4:1

Concrete: Ultimate Loads (lbs.) – Normal-Weight Concrete

Rod Dia. (in.)	Style	Screw Thread Size and Length (in.)	Drill Bit Dia. (in.)	Embed. Depth (in.)	Ultimate					
					2,000 psi		4,000 psi		6,000 psi	
					Tension	Shear	Tension	Shear	Tension	Shear
1/4	Vertical	1/4 x 1-1/4	1/4	1-1/4	1380	1800	1940	2420	2060	2540
3/8	Vertical	1/4 x 1-1/2	1/4	1-1/2	1740	2560	2580	2620	2740	2720
1/2	Vertical	3/8 x 2-3/4	3/8	2-3/4	5300	5220	6000	6300	8580	7400

*Allowable load capacities are calculated using an applied safety factor of 4:1

Concrete: Ultimate and Allowable Loads (lbs.) – Metal Deck Over Structural Lightweight Concrete^{1,3}

Rod Dia. (in.)	Style	Screw Thread Size and Length (in.)	Drill Bit Dia. (in.)	Embed. Depth (in.)	20 Gauge Steel over 3,000 psi – Lightweight Concrete ²			
					Allowable		Ultimate	
					Tension	Shear	Tension	Shear
1/4	Vertical	1/4 x 1-1/4	1/4	1-1/4	195	275	780	1100
3/8	Vertical	1/4 x 1-1/2	1/4	1-1/2	435	360	1740	1440
1/2	Vertical	3/8 x 2-3/4	3/8	2-3/4	950	720	3800	2880

¹ Tabulated loads are for anchors installed with a min. flute edge distance of 1-1/2"

² 5" wide deck tested

³ Allowable load capacities are calculated using an applied safety factor of 4:1

Concrete: Ultimate and Allowable Loads (lbs.) - Hollow Core Concrete Plank^{1,2}

Rod Dia. (in.)	Style	Screw Thread Size and Length (in.)	Drill Bit Dia. (in.)	Embed. Depth (in.)	5,000 psi			
					Center of Web		Center of Core	
					Allowable	Ultimate	Allowable	Ultimate
1/4	Vertical	1/4 x 1-1/4	1/4	1-1/4	680	2720	470	1880
3/8	Vertical	1/4 x 1-1/2	1/4	1-1/2	910	3640	640	2560
1/2	Vertical	3/8 x 2-3/4	3/8	2-3/4	2050	8200	850	3400

¹ 8" thick hollow core plank tested

² Allowable load capacities are calculated using an applied safety factor of 4:1

Order Information



Wood Vertical Hangers: Zinc-Plated Carbon Steel						
Catalog Number	Rod Dia. (in.)	Screw Thread Size and Length (in.)	Point Style	*Drill Bit Dia. (in.)	Box Quantity	Carton Quantity
HTWV141420	1/4	1/4 x 2	Type 17	1/8	100	500
HTWV381410	3/8	1/4 x 1	Type 17		100	500
HTWV381420	3/8	1/4 x 2	Type 17		100	500
HTWV381430	3/8	1/4 x 3	Type 17		100	500
HTWV383822	3/8	3/8 x 2-1/2	Type 17		100	500
HTWV123822	1/2	3/8 x 2-1/2	Type 17		100	500

*If required



Wood Horizontal Hangers: Zinc-Plated Carbon Steel						
Catalog Number	Rod Dia. (in.)	Screw Thread Size and Length (in.)	Point Style	*Drill Bit Dia. (in.)	Box Quantity	Carton Quantity
HTWS381410	3/8	1/4 x 1	Type 17	1/8	100	500
HTWS381420	3/8	1/4 x 2	Type 17		100	500
HTWS383822	3/8	3/8 x 2-1/2	Type 17		100	500

*If required

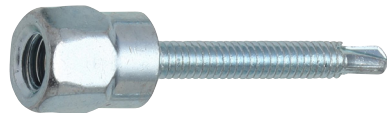

Steel Vertical Hangers (#3 for Purlins, #5 for Beams): Zinc-Plated Carbon Steel						
Catalog Number	Rod Dia. (in.)	Screw Thread Size and Length	Point Style	Self Drilling Range	Box Quantity	Carton Quantity
HTSV141410	1/4	1/4 - 20 x 1	#3	0.036" (20 gauge) to 0.188" (3/16")	100	500
HTSV381420	3/8	1/4 - 20 x 2	#3		100	500
HTSV381410	3/8	1/4 - 20 x 1 (w/nut)	#3		100	500
HTSV381412	3/8	1/4 - 20 x 1-1/2 (w/nut)	#3		100	500
HTSV381212	3/8	1/2 - 20 x 1-1/2 (w/nut)	#5	0.188" (3/16") to 0.500" (1/2")	100	500
HTSV121212	1/2	1/2 - 20 x 1-1/2 (w/nut)	#5		100	500



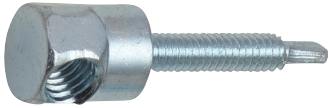

Steel Horizontal Hangers (#3 for Purlins, #5 for Beams): Zinc-Plated Carbon Steel						
Catalog Number	Rod Dia. (in.)	Screw Thread Size and Length (in.)	Point Style	Self Drilling Range	Box Quantity	Carton Quantity
HTSS381410	3/8	1/4 - 20 x 1 (w/nut)	#3	0.036" (20 gauge) to 0.188" (3/16")	100	500
HTSS381412	3/8	1/4 - 20 x 1-1/2 (w/nut)	#3		100	500
HTSS381420	3/8	1/4 - 20 x 2 (w/nut)	#3		100	500



Concrete Vertical Hangers: Zinc-Plated Carbon Steel					
Catalog Number	Rod Dia. (in.)	Screw Thread Size and Length (in.)	Drill Bit Dia. (in.)	Box Quantity	Carton Quantity
HTCV141411	1/4	1/4 x 1-1/4	1/4	200	1000
HTCV381412	3/8	1/4 x 1-1/2	1/4	100	500
HTCV123823	1/2	3/8 x 2-3/4	3/8	50	250

Installation Tools					
Catalog Number	Description/ Size			Box Quantity	Carton Quantity
HTWSST	Universal Steel & Wood Socket			1	10
HTCST14	1/4 Concrete			1	10
HTCST38	3/8 Concrete			1	10
HTCST12	1/2 Concrete			1	10

For more information, please contact:

TOGGLER[®]
HIGH-PERFORMANCE ANCHORS[®]

wej-it[®]
HIGH-PERFORMANCE ANCHORS

Divisions of Mechanical Plastics Corp.
110 Richards Avenue • Norwalk, CT 06854

Phone: 203-857-2200

Fax: 203-857-2201 • E-mail: sales@wejit.com

www.toggler.com • www.wejit.com

Hang-TITE™, TOGGLER logo and typeface, Wej-It® and High-Performance Anchors® are trademarks of Mechanical Plastics Corp. ©2014 Mechanical Plastics Corp. Rev. 8/15